

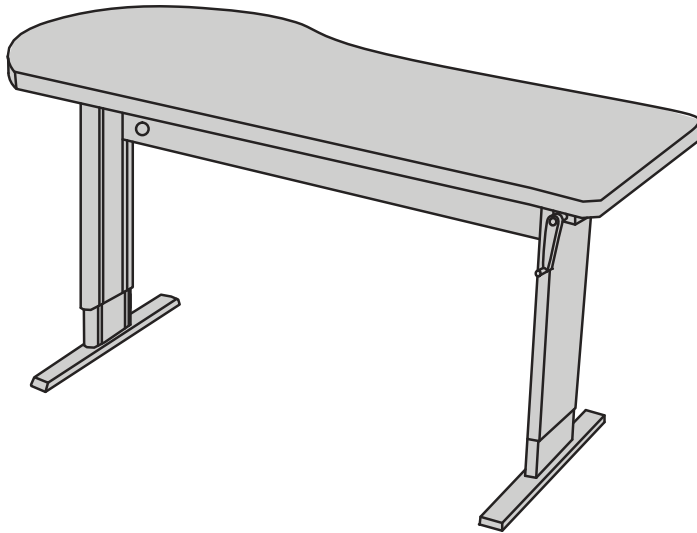

POPULAS
furniture by AD·AS

ACCELLA ENDZONE
Hand-crank, height adjustable table



Sit-to-stand tables, and desks offer our smoothest hand-crank adjustment with the highest weight lifting capacity.

FEATURES:

- Single surface height adjustment for individual positioning or multi-user environment
- Smooth hand-crank adjustment throughout the specified range
- Discreet fold-away crank can be mounted on either side of table
- Durable laminate top or real wood veneer

TECHNICAL DATA:

- Standard table dimensions: 60" X 30"
- Custom workstation top sizes and finishes available
- Vertical adjustment range 27"- 39"
- Hydraulic hand-crank , actuated 5 turns per inch
- Extruded aluminum telescoping legs
- Base finish Graphite Silver
- Load capacity 500 lbs.

MODEL	DIMENSION	ADJUSTMENT RANGE	START/END HEIGHT	LEG SPAN
AC Endzone	60" x 30"	12"	27", 39"	44"

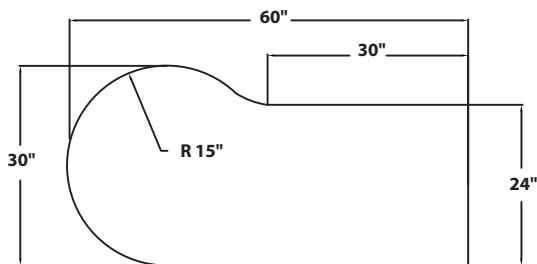

Top View

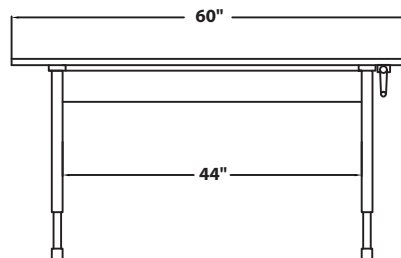

Front View

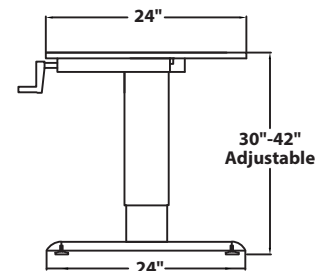

Side View

