

# ASSEMBLY INSTRUCTIONS



## VOX L-SHAPE DESK

Workstations, desks, and tables with powered adjustment

### PARTS INCLUDED:

#### LEG PACKAGE:

- A** (3) Telescoping Legs
- B** (2) Feet
- C** (1) Foot Plate
- D** (3) Table Support Brace
- E** (1) Controller
- F** (1) Control Switch
- G** (4) Cross Brace Bracket
- H** (1) Table Mending Plate
- I** (1) Hardware bag













#### TABLE PACKAGE:

- J** (1) Main Work Surface; (1) Return Work Surface
- K** (2) Cross Brace

#### TOOLS NEEDED:

- Phillips Screwdriver
- 7/16" Open Ended Wrench

### HARDWARE BAG WITH:

<b>L</b> (12) M8 Fasteners		<b>R</b> (4) Connector Caps	
<b>M</b> (12) M6 Fasteners		<b>S</b> (4) Curved Connector Plates	
<b>N</b> (72) #10 x 1" Fasteners		<b>T</b> (2) Double Threaded Rod	
<b>O</b> (20) Clamps (16 small, 4 large)		<b>U</b> (4) 1/4"-20 Nylon Stop Nut	
<b>P</b> (20) #6 x 1/2" Fasteners		<b>V</b> (8) 1/4"-20 Fasteners, Washers, and Nuts	
<b>Q</b> (2) #8 x 3/4" Fasteners		<b>W</b> (5) Levelers	
		<b>X</b> Allen Keys	

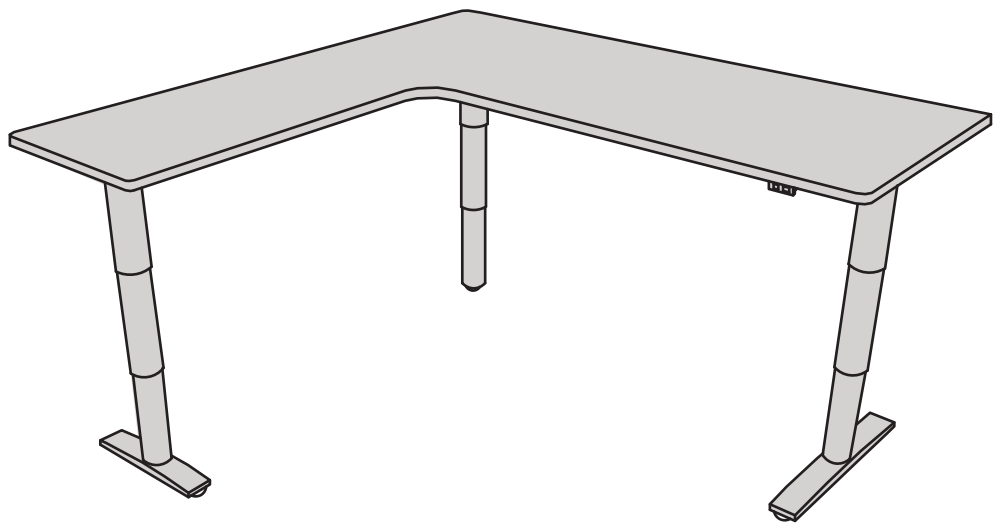

Instructions for Models: VX 7230 L, VX 727230 PC, VX 727224 PC, VX 727230 WC, VX 727224 WC

## STEP 1: PREPARATION

Unpack and identify all parts. Place Work Surfaces (J) upside down on padded surface and identify Front Edge.

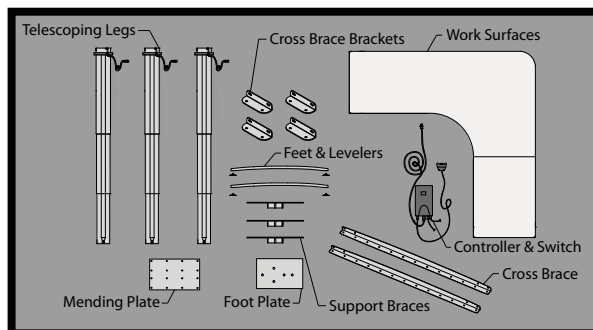

## STEP 2: WORK SURFACE ATTACHMENT

Place Curved Connector Plates (S) in connector holes. Insert Double Threaded Rod (T) into side holes of Work Surface. Gently slide and align the two Work Surfaces together.

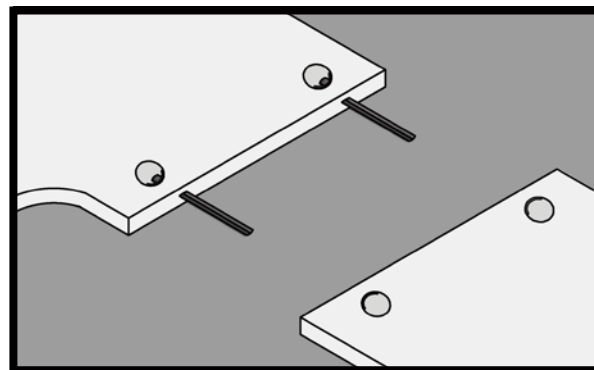

Secure the two Work Surfaces together with ¼"-20 Nylon Stop Nuts (U).

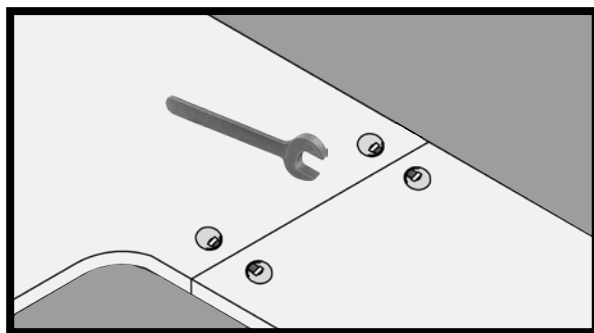

Attach Table Mending Plate (H) to Work Surfaces using sixteen #10 x 1 Fasteners (N) as shown. Insert four Connector Caps (R) into connector holes.

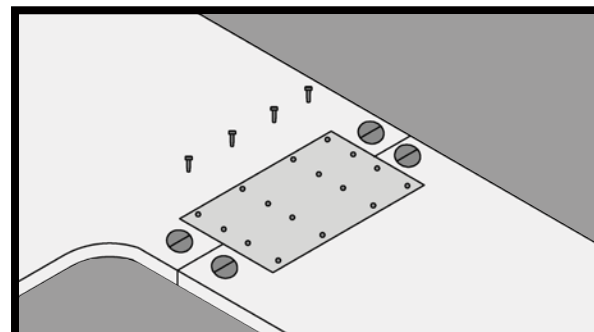

### STEP 3: SUPPORT BRACE ATTACHMENT TO TELESCOPING LEG

Position Table Support Brace (D) over Telescoping Leg (A) as shown. Align the slot in the support brace with the cable exit and securely attach cable in cable cradle. Secure Table Support Brace to Telescoping Legs with four M6 Fasteners (M).

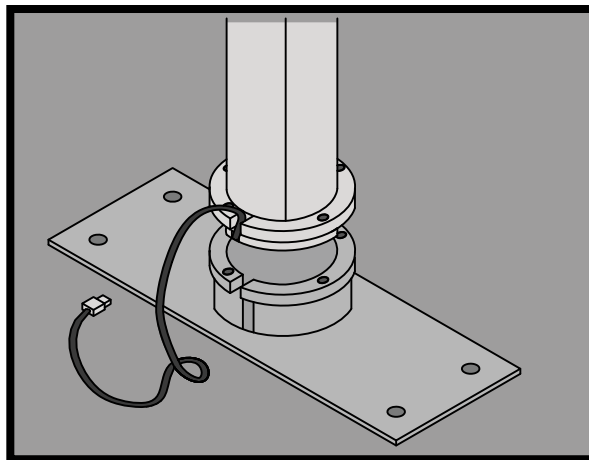

### STEP 4: TABLE SUPPORT BRACE AND CROSS BRACE ATTACHMENT TO WORK SURFACE

Position Table Support Braces (D) as shown with the cables facing inward. Align with pre-drilled holes. Position Cross Brace Brackets (G) on the back portion of Table Support Brace (D). Position Cross Braces (K) and join to Cross Brace Brackets (G) using  $\frac{1}{4}$ -20 Fasteners, Washers, and Nuts (V) as shown. Attach Support Brace to Work Surface with six #10 x 1" Fasteners (N). Attach Cross Braces (K) to Work Surface with #10 x 1 Fasteners as shown.

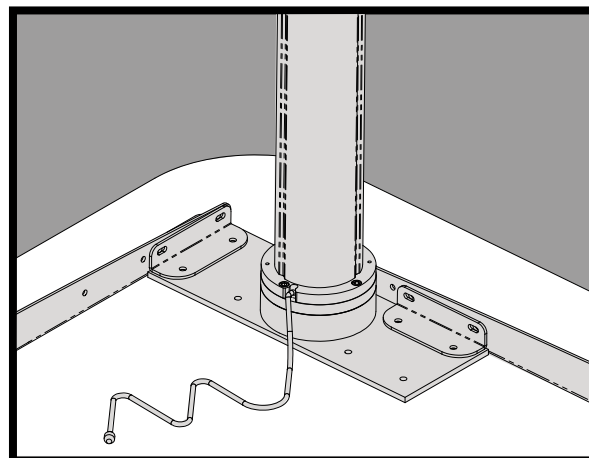
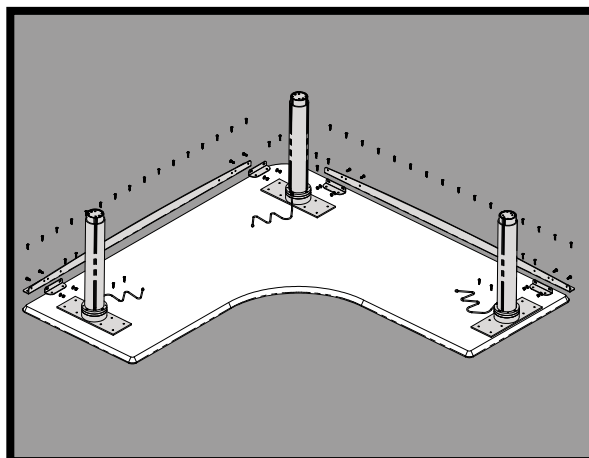
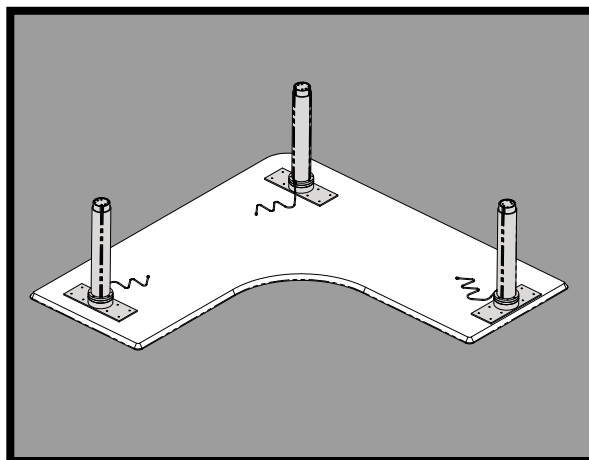

## STEP 5: CONTROLLER AND CONTROL SWITCH ATTACHMENT

Position Controller (E) and Control Switch (F) as shown on Work Surface. Align with pre-drilled holes and attach Controller to Work Surface as shown using two #10 x 1" Fasteners (N). Plug power cord into Controller (E). Plug each cable from the Telescoping Legs (A) into the M1, M2, and M3 slots. Plug the Control Switch (F) into the HS Slot. Attach Control Switch with two #8 x ¾" Fasteners (Q). Control Switch can be mounted left or right. Secure all cables and wires with Clamps (O) and #6 x ½" Fasteners (P) as shown. Coil any excess cable.

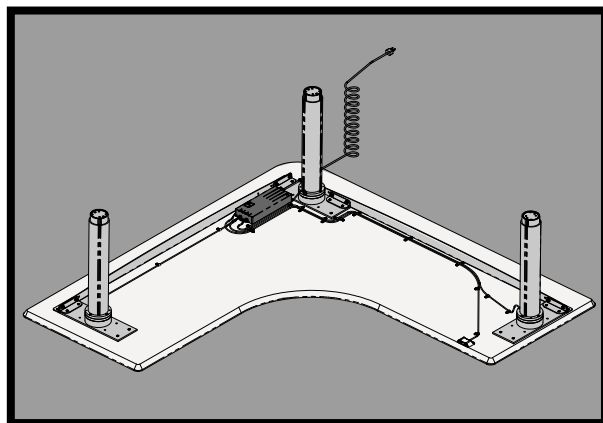

## STEP 6: FEET AND FOOT PLATE ATTACHMENT

Attach Feet (B) to bottom of the outer Telescoping Legs (A), and Foot Plate (C) over the center Telescoping Leg. Align with mounting holes and attach using four M8 Fasteners (L) but do not completely tighten. The mounting plate on the Telescoping Leg will swivel allowing the feet to be aligned properly. Securely holding the feet in the proper alignment with the Work Surface, fully tighten the Fasteners. Position the Foot Plate (C) with thread for Leveler facing inward. Attach five Levelers (W) or optional casters.

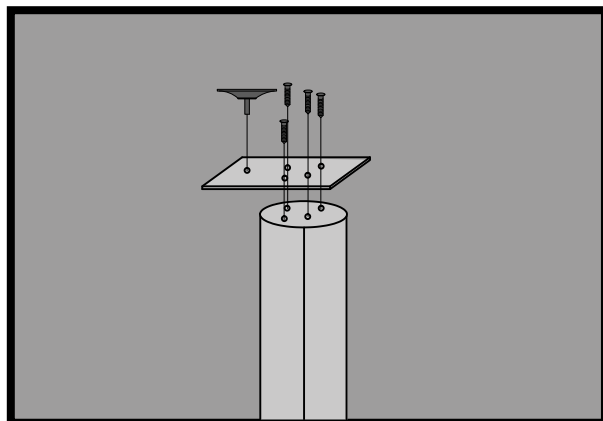
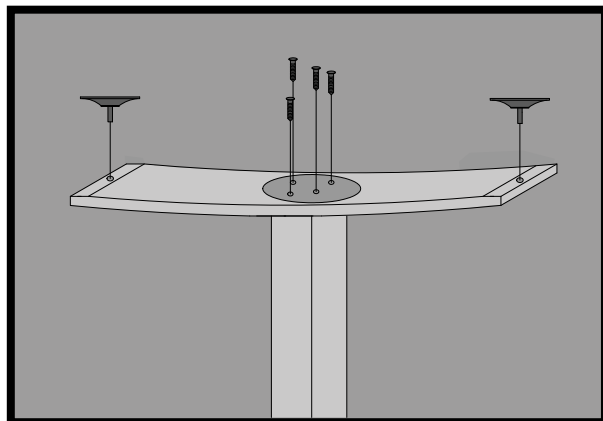

## STEP 7: OPERATION AND USE

Caution: Desk is heavy and requires more than one person to turn over. Gently turn table over and adjust Levelers (W) if required. The table adjusts up and down using the Control Switch (F). Clean with soft cloth and mild cleaners suitable for furniture.



### VOX SYSTEM CONTROLLER RESET PROCEDURE

---

The following instructions can be used to perform the reset procedure on Vox powered workstations. These instructions should be used if a new controller is introduced to the system, the limits have changed on the controller, or if the system is simply behaving unexpectedly. To reset the controller:

- Remove the motor cables from the “M” slots on the controller (M1, M2, etc.)
- Press and hold the down button on the switch until a “double click” is heard. This should take approximately 7-10 seconds from the first click.
- Plug all motor cables back in to their respective “M” slots on the controller.
- Press the down button on the switch; at this point, all legs should begin slowly creeping downward to the “zero” (fully retracted) position.
- Continue holding the down button until the system has reached its “zero” position. At this point, press and hold the down button again, and the system will step forward to its “home” position.

At this point, your Vox workstation should be reset to its home position. To verify, try operating the system by moving it upwards with the up button, and again downwards; ensure the system returns to the home position.

# OPTIONAL PROGRAMMABLE CONTROL SWITCH INSTRUCTIONS

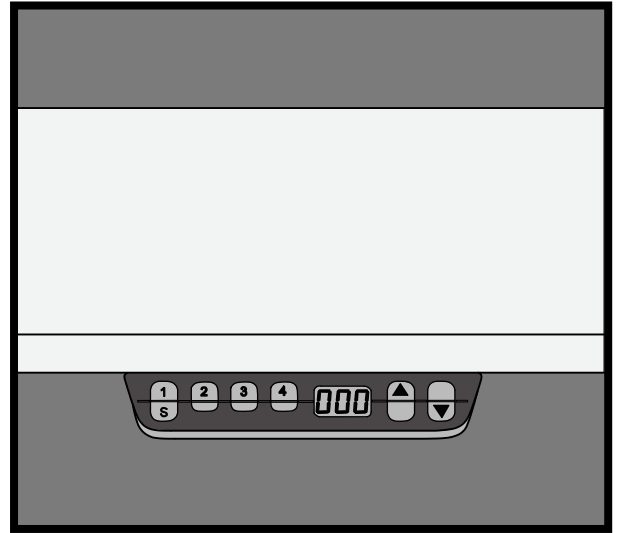

User Manual  
LogicS-2 / LogicS-3

## 4.2 Advanced Functionality









Note: Functionality described in this chapter is only accessible if you have a handset with position keys and a save key!

### 4.2.1. Saving a Position

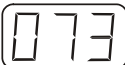
This function allows to save one desk-height per position key. To save a desk position, proceed as follows:

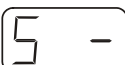

Note: On initial operation all stored positions are equal to the lowest possible desk-height (lower end position).

-  Move the desk to the position you want to save.  
 The display reads the actual height of the desk (e.g. 73cm).
-  Press the S key.  
 The display reads S -.
-  Press the desired position key (e.g. T2).  
 The display reads S 2.
- Now the height is saved on the chosen position key  
 The saving operation is confirmed with a double-click sound and after appr. 2 seconds the storage height will be displayed.



Note: The position keys may have varying design, depending on the kind of handset used.

## OPTIONAL PROGRAMABLE CONTROL SWITCH INSTRUCTIONS (CONTINUED)

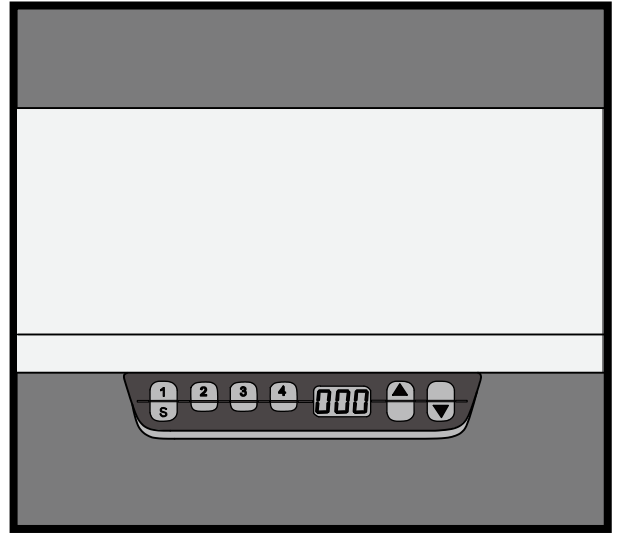

User Manual  
LogicS-2 / LogicS-3

---

### 4.2.2. Moving to a Saved Position

This function allows to move the desk to a saved position. To move to a saved position, proceed as follows:



Note: Whether the double-click automatic function is available or not, depends on the software configuration of the control box.

---

#### Alternative A (without automatic function)

-  Press and hold the desired position key (e.g. 2).  
The desk will move until the saved position is reached.  
If you release the key before reaching the saved position, the desk stops and the saved position will not be reached.
- The desk has reached the saved height. Release the position key.

 The display reads the actual desk-height.

#### Alternative B (with double-click automatic function)

-  Double-click the desired position key (e.g. 2)
- The desk automatically moves to the saved position.

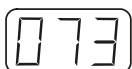
 The display reads the actual desk-height.



Note: If you press any key while the desk is automatically moving, the desk will immediately stop. To continue, you have to repeat the above procedure.