



EQUITY BI-LEVEL WORKSTATION

Computer workstation with hand-crank adjustment

Parts Included

Leg Package:

- (4) Legs (2A and 2B)
- (4) Leg Top Plates
- (2) Feet
- (4) Toe Caps
- (1) Front Hand-crank Assembly with Gearbox
- (1) Top Crank Assembly
- (2) Drive Shaft Assembly
- (1) Hardware Bag

Table Package:

- (1) Cross Brace
- (2) Table Tops

Tools Needed:

- #2 Phillips Screwdriver or Power Driver

Hardware

Hardware Bag with:

- (2) Cross Brace Brackets

- (8) $\frac{3}{8}$ " Cross Brace Bracket Fasteners

- (4) #8 x $1\frac{3}{4}$ " Wood Screws

- (16) $\frac{1}{4}$ " x $\frac{3}{4}$ " Fasteners

- (44) #10 x 1" Screws for Leg Top Plates

- (8) $\frac{5}{16}$ " x 1" Fasteners

- (8) $\frac{5}{16}$ " Lock Washer

- (4) Levelers (or optional casters)

- (1) $\frac{5}{32}$ " Allen Wrench

- (1) $\frac{3}{16}$ " Allen Wrench

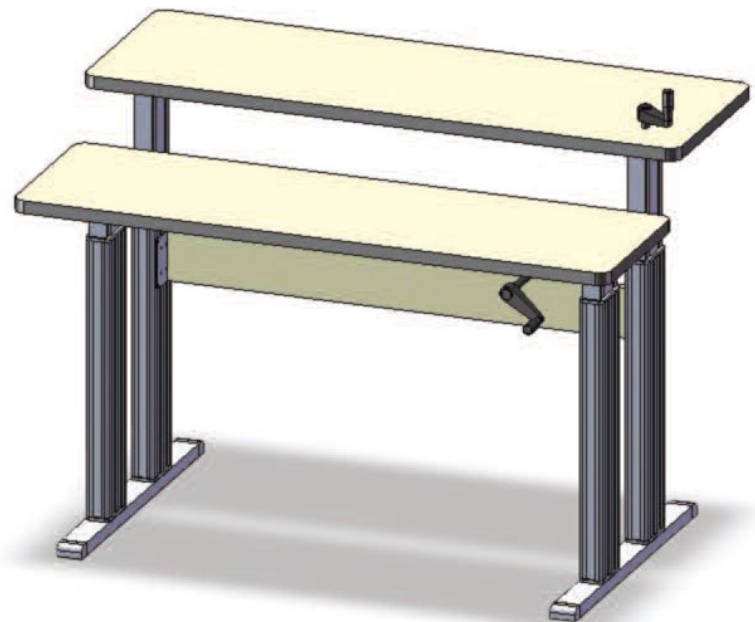

STEP ONE

Unpack and identify all parts.

Place table tops upside down on padded surface and identify front edge.

STEP TWO

Identify the legs (A and B) and their orientation as shown in the diagram.



Look at the bottom of the leg to identify the leg letter (A or B).



Legs must be positioned in correct orientation to operate. Shaft couplers face inward.

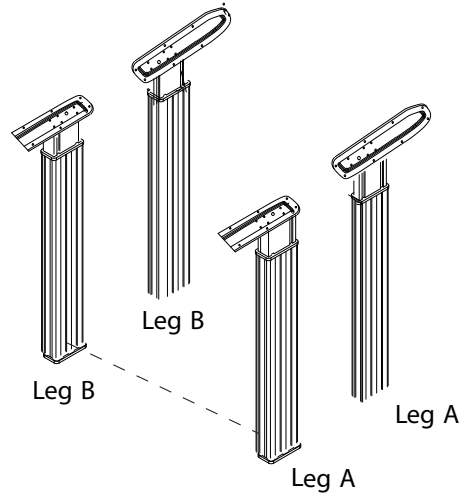

STEP THREE

Attach leg top plates to legs using four 1/4" button head fastener per plate as shown.



Leg Top Plates orientation is different for front table surface and rear table surface.

There are two sets of plates, (2)14"x3" and (2)10"x3". The long plates are for the Rear Surface (16"), the short plates are for the Front Surface (14"). All four plates will line up to the corresponding pre-drilled holes.

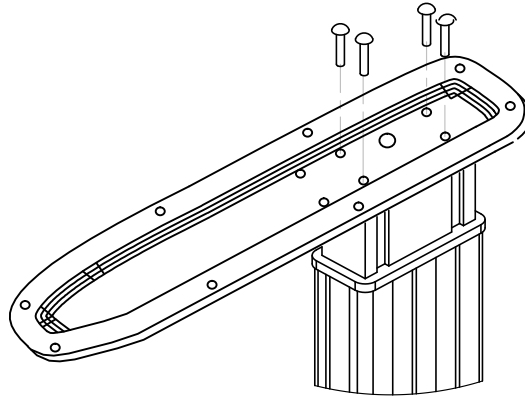

STEP FOUR

Attach feet to legs using four 5/16" button head fasteners and lock washers per foot.

Insert toe caps and levelers.



Shorter length of foot from leg is toward the front.

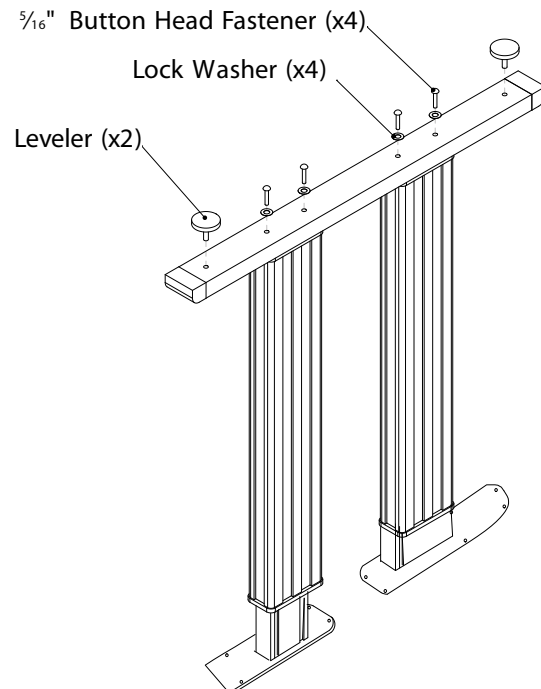

STEP FIVE

Attach cross brace bracket to cross brace using four #8 1 $\frac{3}{4}$ " screws as shown.

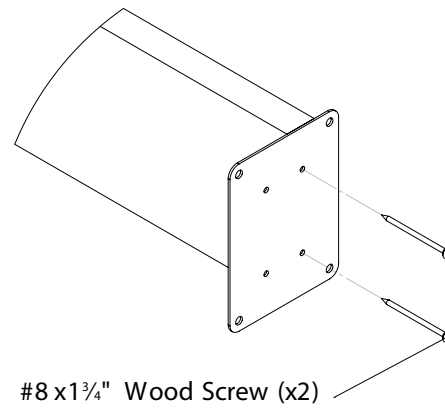

Attach cross brace bracket to rear legs as shown.

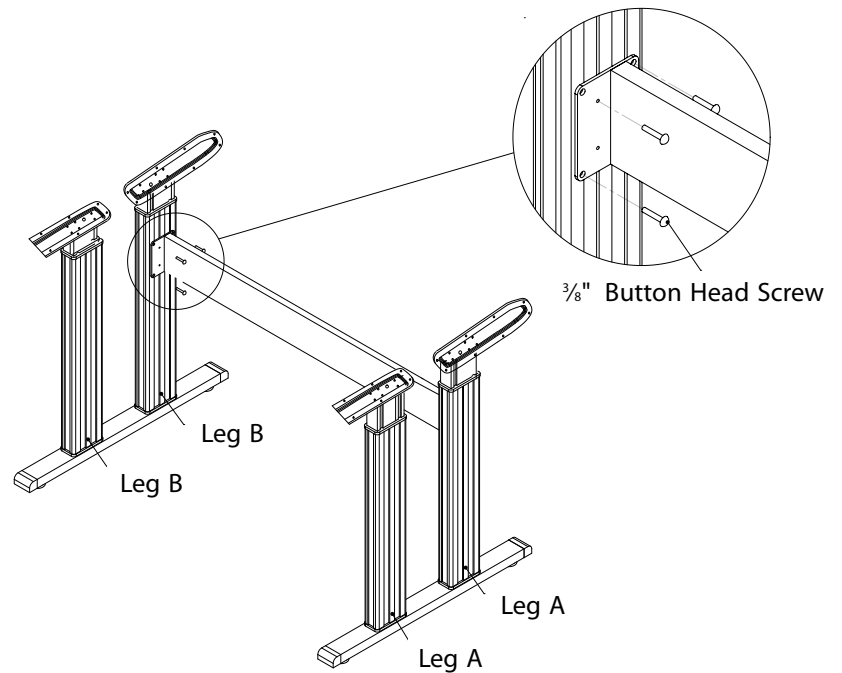

STEP SIX

Slide gear box over hexagonal shaft as shown for front surface only.

Insert hexagonal shafts fully into legs (front and rear).

Slide washer flush to connector tube and center tube between legs.

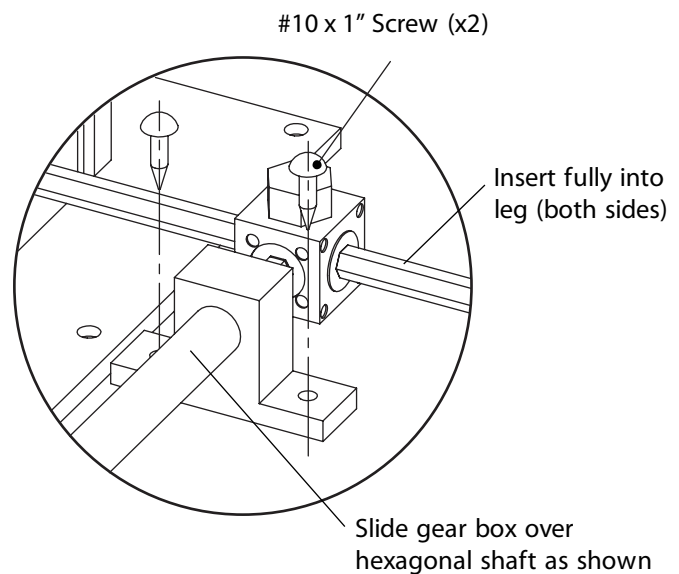

STEP SEVEN

Attach mounting plates to tabletops using #10 x 1" screws.

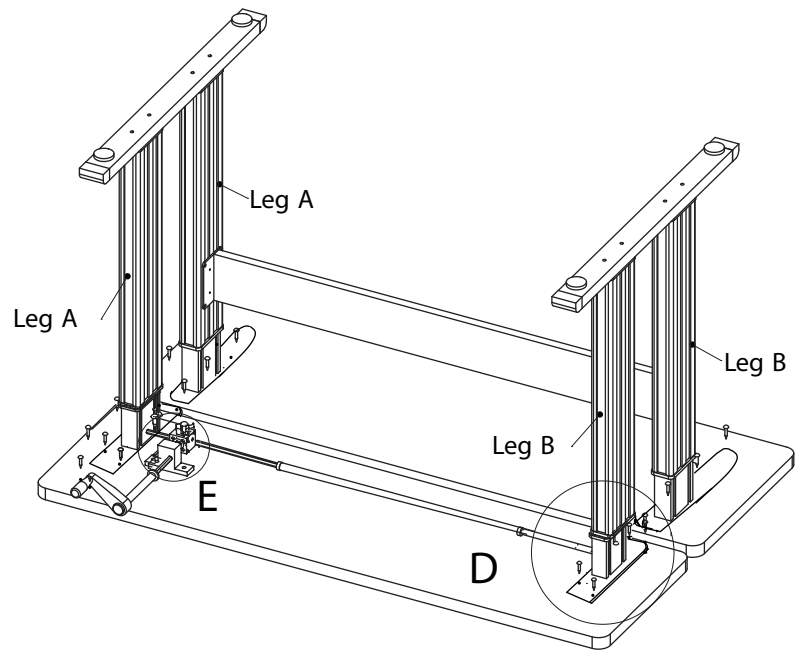

#10 x 1" Screws (x6)

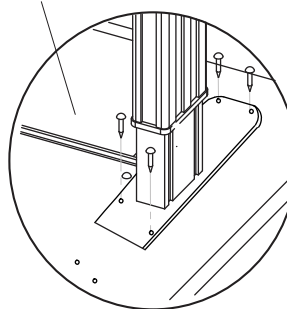

Detail : D

Attach hand crank brackets to front table top using #10 x 1" screws.

#10x 1" Screw (x4)

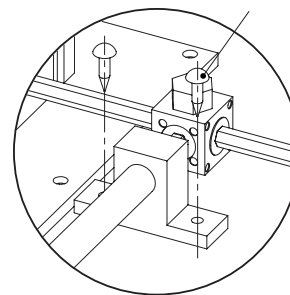

Detail : E

STEP EIGHT

Gently turn table over and adjust levelers if required.

Insert the topcrank handle through the rear table top directly into the crank tube.

Pull the front crank handle out and raise and lower table. The front crank handle slides underneath the table if desired. Clean with soft cloth and mild cleaners suitable for furniture.